

OUTSIDE DIMENSIONS

Dimensions in mm

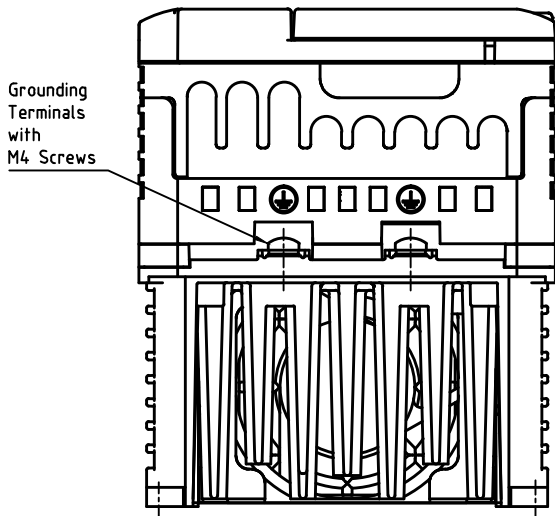

許容スペース
Minimum allowable space

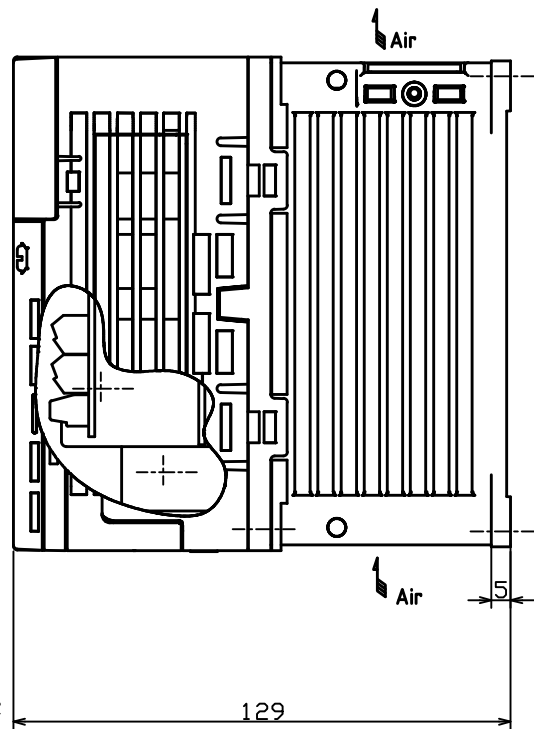
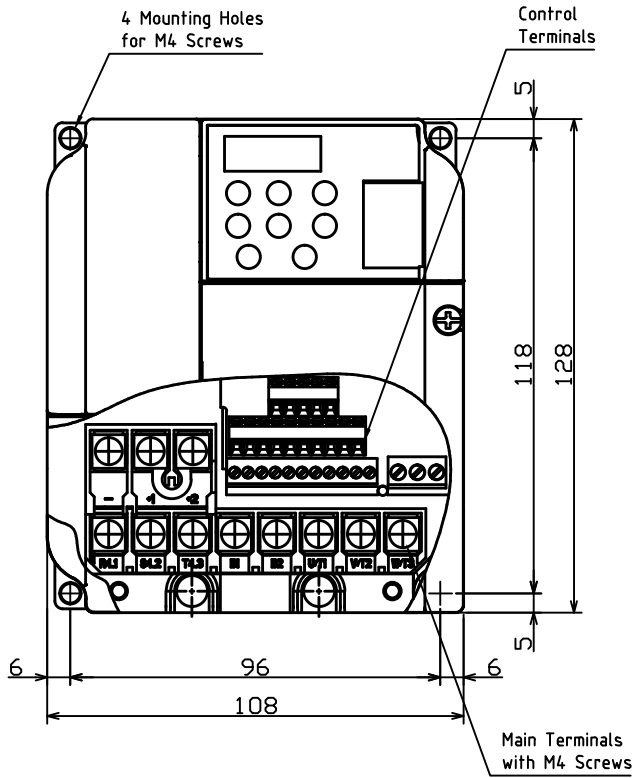
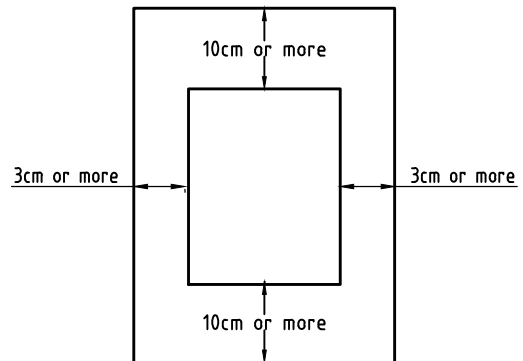

Mass: 1.7kg

HF5202-1A5, HFX202-1A5

ご注文主: Customer:	△	Inverter HF-520/HF-X20 1.5kW/3φ200V
製番: Manuf. No.:	△	
台数: On Order:	△	
 		DWG. No. JT522AW DATE APR. 18. 2014