

# OUTSIDE DIMENSIONS

Dimensions  
in mm

操作パネル  
Digital Operator Panel

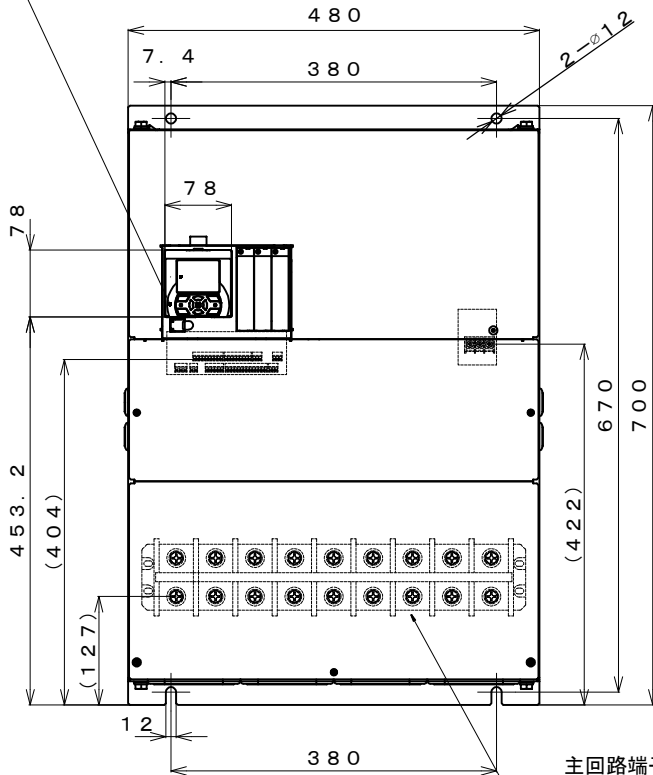

制御電源端子台  
Control Power Supply Terminal  
W=9.8 M4  
締め付けトルク  
Tightening Torque 1.2~1.4 N·m

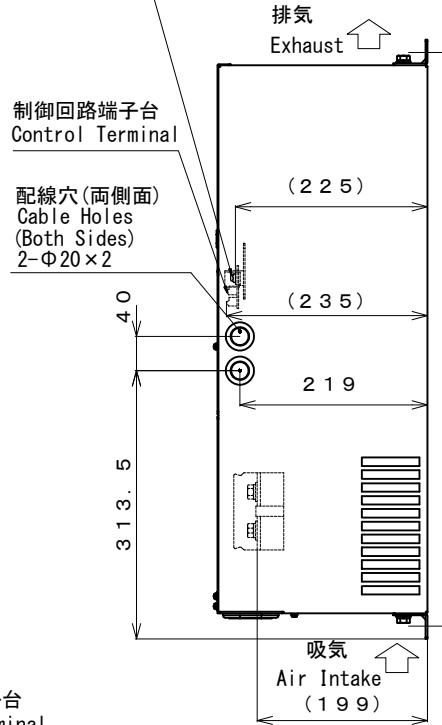

主回路端子台  
Mains Terminal  
W=40 M10  
締め付けトルク  
Tightening Torque 10~12 N·m

許容スペース  
Minimum allowable space

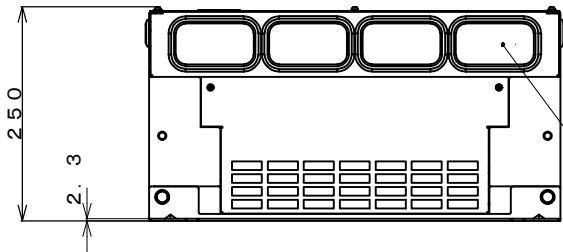

配線穴  
Cable Holes  
4- $\phi 91 \times 48$

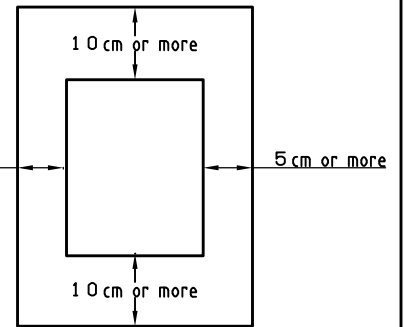

Mass: 47kg

HF4322-055

ご注文主: Customer:	△	Inverter
製番: Manuf. No.:	△	
台数: On Order:	△	

HF-430NE0  
55kW/3 $\phi$  200V

Sumitomo Drive Technologies

Sumitomo Heavy Industries, Ltd.

DWG. No. JT581AW

DATE MAR. 20. 2020