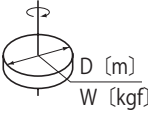
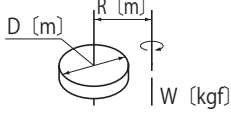
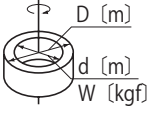
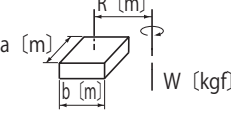
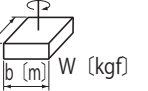
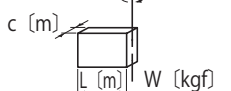
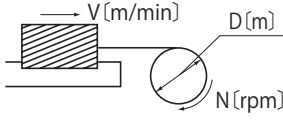
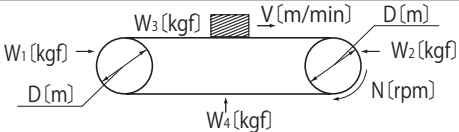
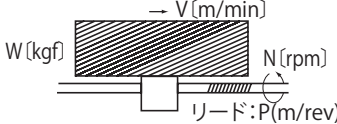
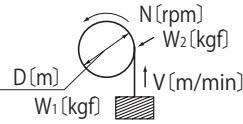

GD² の計算式

(1) 回転体のGD²

回転軸が重心を通る場合		回転軸が重心を通らない場合	
	$GD^2 = \frac{1}{2}WD^2$ [kgf・m ²]		$GD^2 = W \left(\frac{1}{2}D^2 + 4R^2 \right)$ [kgf・m ²]
	$GD^2 = \frac{1}{2}W(D^2 + d^2)$ [kgf・m ²]		$GD^2 = W \left(\frac{a^2 + b^2}{3} + 4R^2 \right)$ [kgf・m ²]
	$GD^2 = \frac{1}{3}W(a^2 + b^2)$ [kgf・m ²]		$GD^2 = \frac{1}{3}W(4L^2 + c^2)$ [kgf・m ²]

(2) 直線運動のGD²

一般用途		$GD^2 = W \left(\frac{V}{\pi \cdot N} \right)^2 = WD^2$ [kgf・m ²]
コンベアによる水平運動		$GD^2 = \left(\frac{W_1 + W_2 + W_3 + W_4}{2} \right) \times D^2$ [kgf・m ²]
リードネジによる水平運動		$GD^2 = W \left(\frac{V}{\pi \cdot N} \right)^2 = W \left(\frac{P}{\pi} \right)^2$ [kgf・m ²]
巻き上げ機による上下運動		$GD^2 = W_1 D^2 + \frac{1}{2} W_2 D^2$ [kgf・m ²]

(3) 回転数が異なる軸への換算

	$GD^2 = \left(\frac{N_2}{N_1} \right)^2 GD^2$
---	--