

OUTSIDE DIMENSIONS

Dimensions in mm

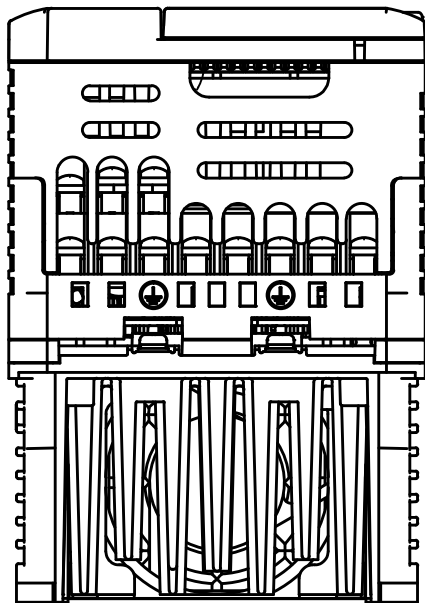

許容スペース
Minimum allowable space

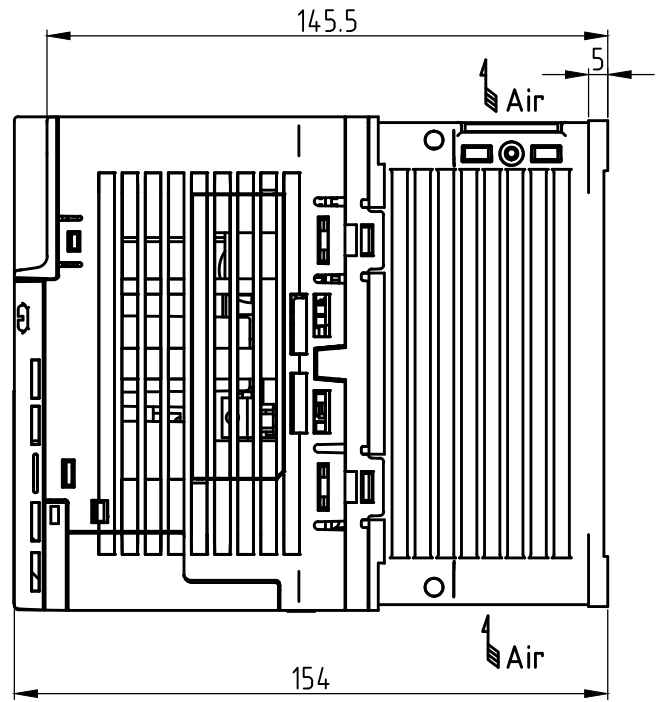
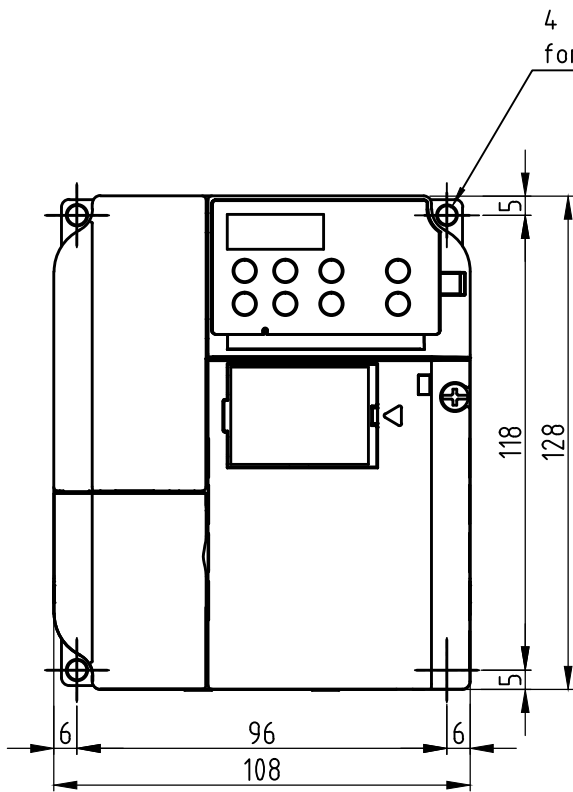
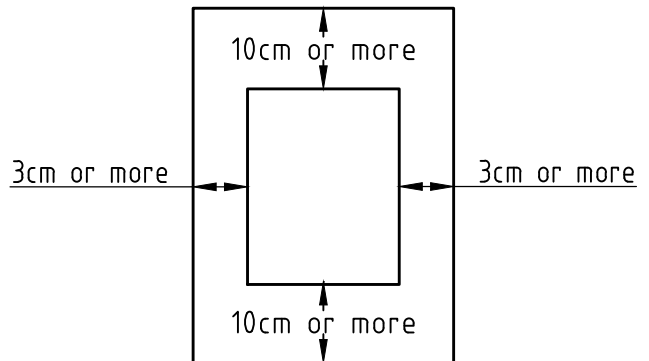

Mass: 1.7kg

SF5204-1A5, 2A2

ご注文主: Customer:	△	Inverter SF-520 1.5, 2.2kW/3φ400V
製番: Manuf. No.:	△	
台数: On Order:	△	

Sumitomo Drive Technologies

Sumitomo Heavy Industries, Ltd.

DWG. No. **JT546AW**

DATE **JUL. 7. 2014**