

# OUTSIDE DIMENSIONS

Dimensions in mm

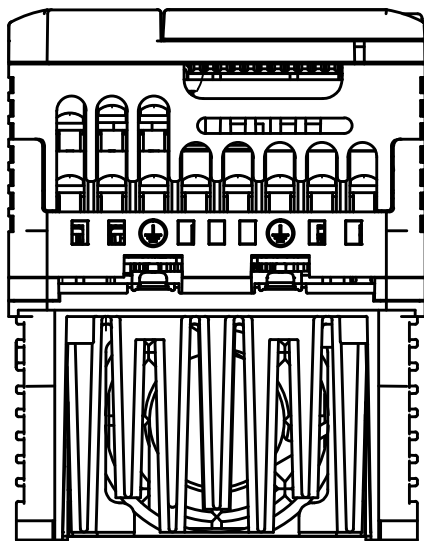

許容スペース  
Minimum allowable space

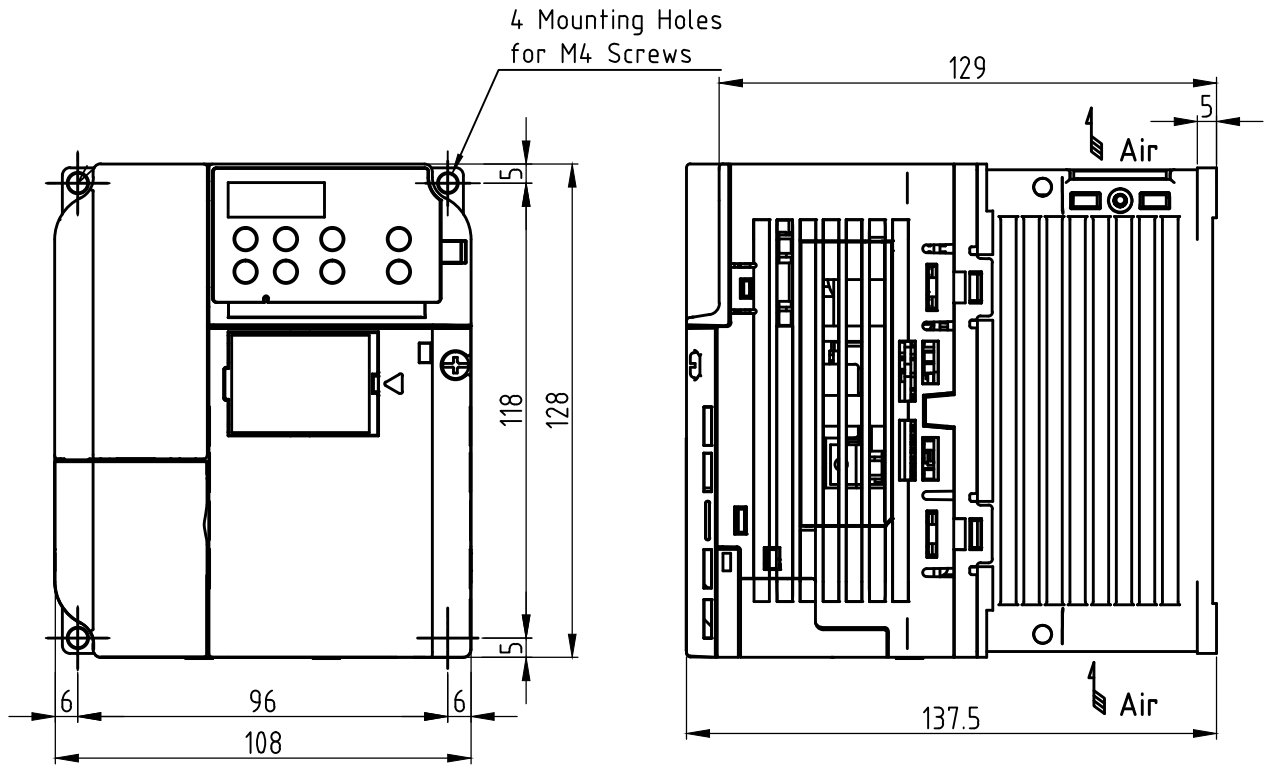
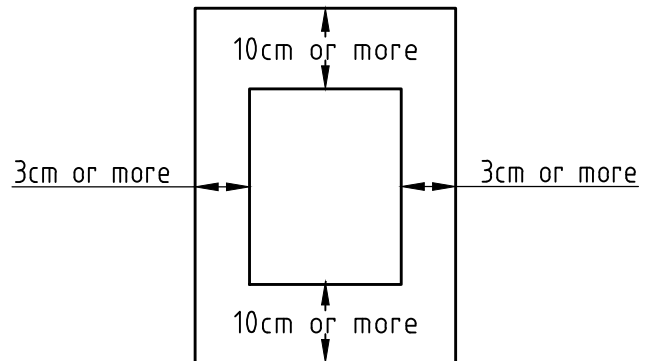

Mass: 1.7kg

SF5202-2A2

ご注文主: Customer:	△	Inverter <b>SF-520</b> 2.2kW/3φ200V
製番: Manuf. No.:	△	
台数: On Order:	△	
<b>Sumitomo Drive Technologies</b> Sumitomo Heavy Industries, Ltd.		DWG. No. <b>JT540AW</b>
		DATE <b>JUL. 7. 2014</b>