

OUTSIDE DIMENSIONS

Dimensions in mm

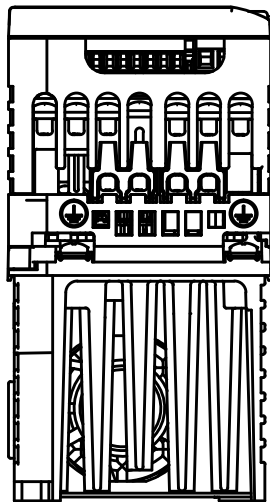

許容スペース
Minimum allowable space

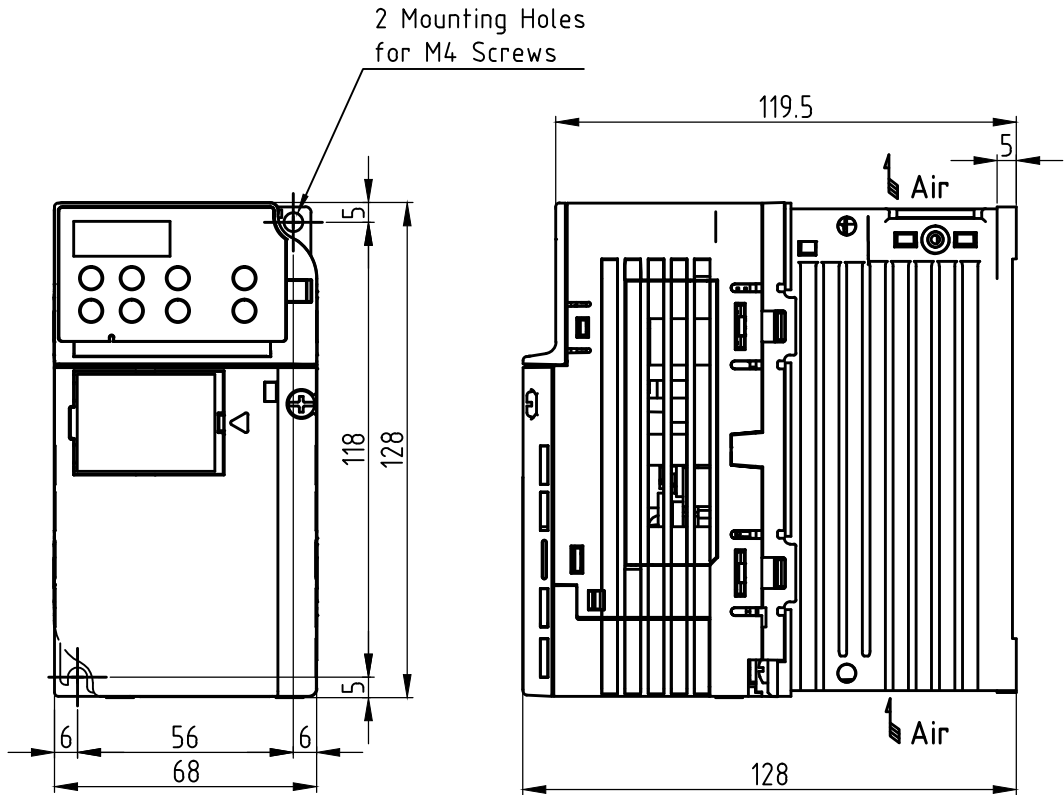
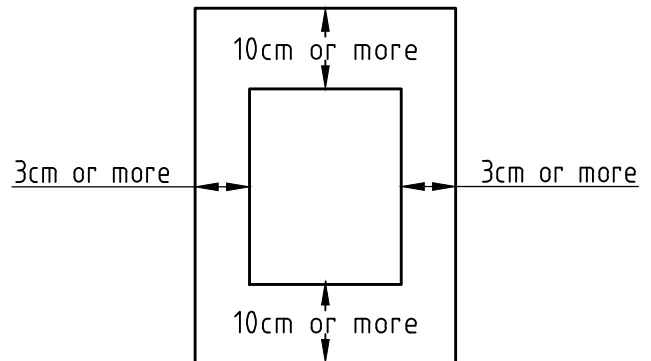

Mass: 1.1kg

SF520-A75

ご注文主: Customer:	△	Inverter SF-520 0.75kW/3φ200V
製番: Manuf. No.:	△	
台数: On Order:	△	
Sumitomo Drive Technologies Sumitomo Heavy Industries, Ltd.		DWG. No. JT538AW DATE JUL. 7. 2014